

ASM24BC-HF

RoHS Device
Halogen Free

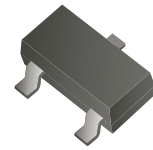

Features

- ESD/ transient protection of high speed data lines.
IEC 61000-4-2 (ESD): $\pm 30\text{kV}$ (air), $\pm 30\text{kV}$ (contact).
- Working voltage: $V_{RWM}=24\text{V}$.
- AEC-Q101 Qualified.

Mechanical data

- Case: SOT-23, molded plastic.
- Molding compound: UL flammability classification rating 94V-0.
- Terminals: Matte tin-plated leads, solderability per MIL-STD-202, method 208.
- Mounting position: Any.

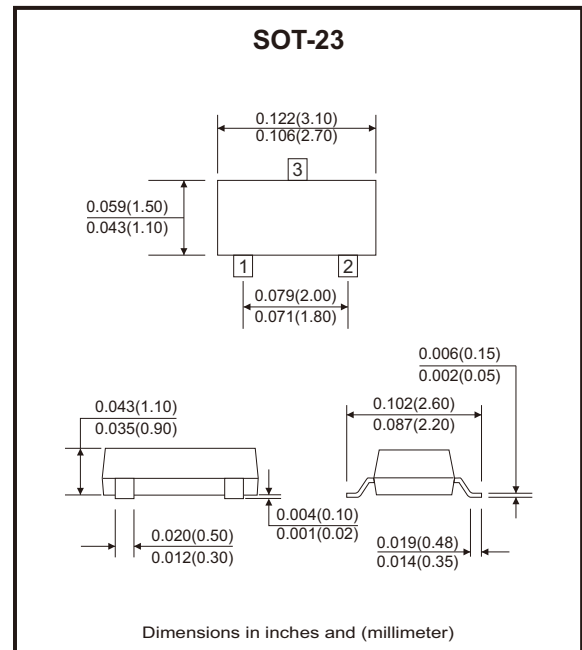

Circuit Diagram

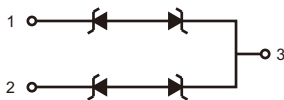

Maximum Rating (at $T_A=25^\circ\text{C}$ unless otherwise noted)

Parameter	Symbol	Value	Unit
IEC 61000-4-2; ESD (air)	V_{ESD-A}	± 30	kV
IEC 61000-4-2; ESD (contact)	V_{ESD-C}	± 30	kV
Peak pulse power ($t_p = 8/20\mu\text{s}$)	P_{PP}	364	W
Peak pulse current ($t_p = 8/20\mu\text{s}$)	I_{PP}	7	A
Junction temperature range	T_j	-55 to +125	$^\circ\text{C}$
Storage temperature range	T_{STG}	-55 to +150	$^\circ\text{C}$

Electrical Characteristics (at TA=25°C unless otherwise noted)

Parameter	Conditions	Symbol	Min	Typ	Max	Unit
Reverse stand-off voltage		V_{RWM}			24	V
Reverse breakdown voltage	$I_T = 1\text{mA}$	$V_{(BR)}$	26.2		32	V
Reverse leakage current	$V_{RWM} = 24\text{V}$	I_R			0.1	μA
Clamping voltage	$I_{PP} = 1\text{A}, t_p = 8/20\mu\text{s}$	V_C			40	V
	$I_{PP} = 5\text{A}, t_p = 8/20\mu\text{s}$	V_C			45	
	$I_{PP} = 7\text{A}, t_p = 8/20\mu\text{s}$	V_C			52	
Junction capacitance	$V_R = 0\text{V}, f = 1\text{MHz}, (\text{Line to GND})$	C_J			30	pF

Rating and Characteristic Curves (ASM24BC-HF)

Fig.1 - 8/20 μs waveform per IEC 61000-4-5

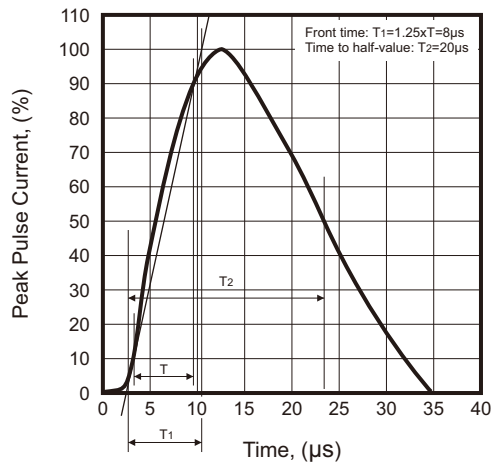

Fig.2 - ESD Pulse Waveform According to IEC 61000-4-2

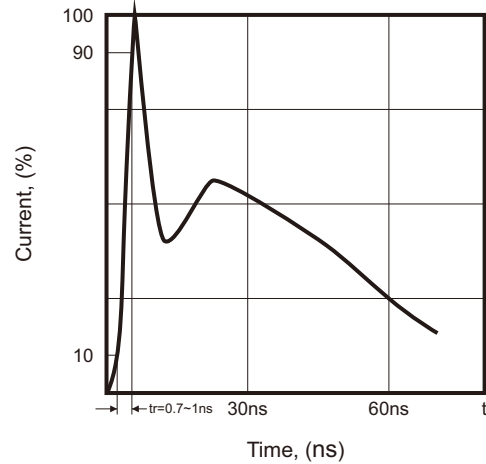
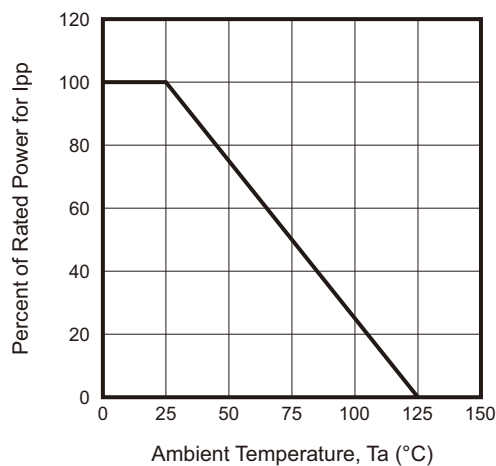
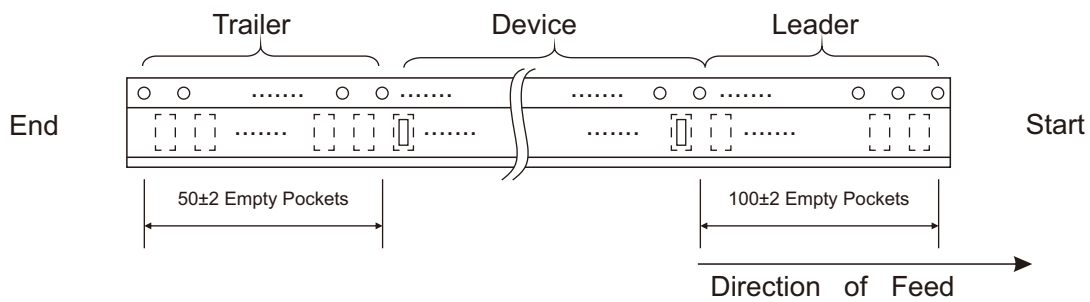
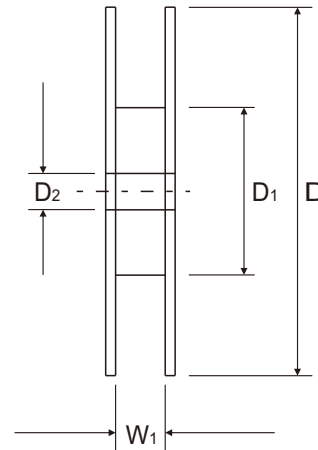
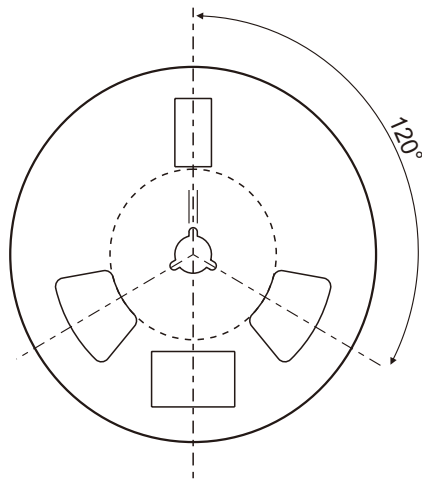
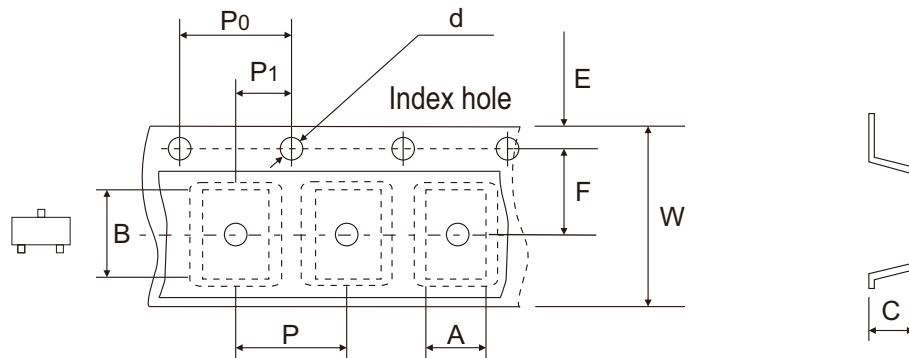

Fig.3 - Power Derating Curve



Reel Taping Specification



SOT-23	SYMBOL	A	B	C	d	D	D1	D2
	(mm)	3.15 ± 0.10	2.77 ± 0.10	1.22 ± 0.10	1.50 ± 0.10	178.00 ± 1.00	54.00 ± 0.50	13.00 ± 0.50
	(inch)	0.124 ± 0.004	0.109 ± 0.004	0.048 ± 0.004	0.059 ± 0.004	7.008 ± 0.039	2.126 ± 0.020	0.512 ± 0.020

SOT-23	SYMBOL	E	F	P	P0	P1	W	W1
	(mm)	1.75 ± 0.10	3.50 ± 0.05	4.00 ± 0.10	4.00 ± 0.10	2.00 ± 0.05	8.00 + 0.30 - 0.10	9.50 ± 1.00
	(inch)	0.069 ± 0.004	0.138 ± 0.002	0.157 ± 0.004	0.157 ± 0.004	0.079 ± 0.002	0.315 + 0.012 - 0.004	0.374 ± 0.039

Marking Code

Part Number	Marking Code	
	ASM24BC-HF	M24BC

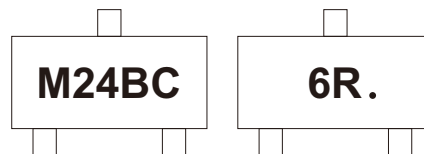

Suggested P.C.B. PAD Layout

SIZE	SOT-23	
	(mm)	(inch)
A	0.90	0.035
B	0.80	0.031
C	0.95	0.037
D	2.00	0.079
E	2.90	0.114

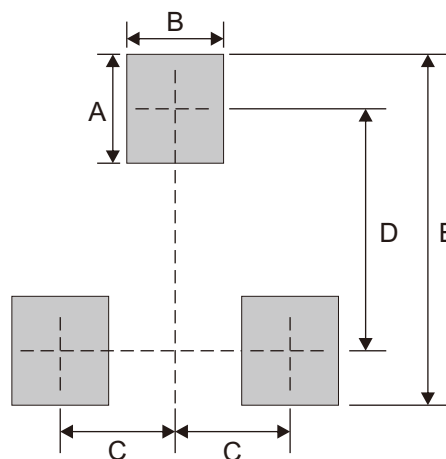

Standard Packaging

Case Type	REEL PACK	
	REEL (pcs)	Reel Size (inch)
SOT-23	3,000	7